

BREAD AND PASTRY



Stratos XP

 **POLIN**[®]

EN

4.0
INDUSTRY





All the pastries you want, from light to large proofed products

Space for your art as a pastry cook.

Stratos XP allows you to bake all kinds of products perfectly: from the smallest and lightest to large proofed products. You can delight your customers with a rich, tempting and creative display cabinet.

Stratos XP is a 4.0 modular electric oven equipped with all the latest technology to ensure quality, speed and repeatability from the first to the last batch.



Excellent baking with every preparation:

a unique heat system keeps the temperature even at all times in all areas of the chamber, and allows you to set up to 10 stages for each baking cycle.



Specific functions for pastries.

Using the Hybrid Control system, you can set automatic baking cycles and make the most of smart features for full control over the baking process.

Temperature precision and consistency allows you to achieve your desired end result every time.





Full speed bread! From hard to hydrated doughs

Your Bakery Chef creativity will know no limits.

Every day you will have perfectly baked products:

small, medium and large breads, plain or filled, sweet or savoury, anything you need to satisfy your customers' palates.

With Stratos XP you can bake high-quality products in no time.



Ideal heat. Right to the heart of every product.

Stratos XP always ensures gentle, enveloping heat: the ideal thermal conditions for optimal product development.



Steam as you need it, whatever the oven temperature.

The Stratos XP steamer quickly generates all the steam you need: autonomous and independent, it gives you steam when you need it and also ensures complete saturation when the oven is fully loaded.



Specific functions for bread-making.

Using the Hybrid Control system, you can set automatic baking cycles and make the most of smart features for full control over the bread-baking process.

The modular electric oven at its best



Stratos XP 4STL with proofing chamber

Stratos XP is a versatile, adaptable oven featuring a singular system based on exclusive patented technology that consistently delivers uniform baking. Each chamber has been fitted with the new Hybrid Control panel which gives you fuss-free control over the special exclusive functions designed to boost oven performance levels.

Stratos XP is also available in a **Super Power** version which allows you to double the oven performance. It is recommended for high-productivity requirements.

Baking plate in perforated sheet metal

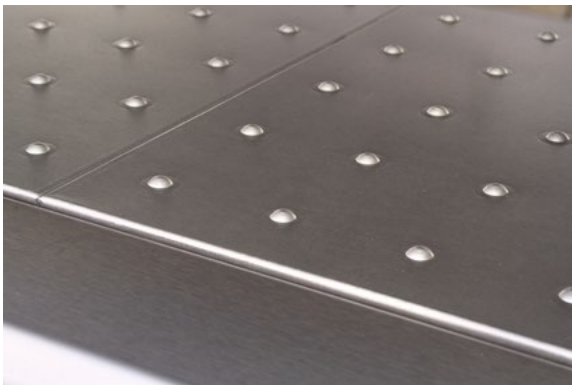
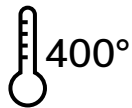

Baking plate in reinforced concrete

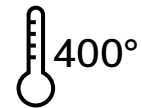

Baking plate in fibre cement

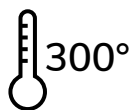

Baking plate in refractory material



Flexibility and stability at the set temperature

Stratos XP quickly reaches the set temperature and activates the exclusive dynamic control system (PID), ensuring that any deviation from the set value is absolutely minimal.

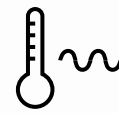
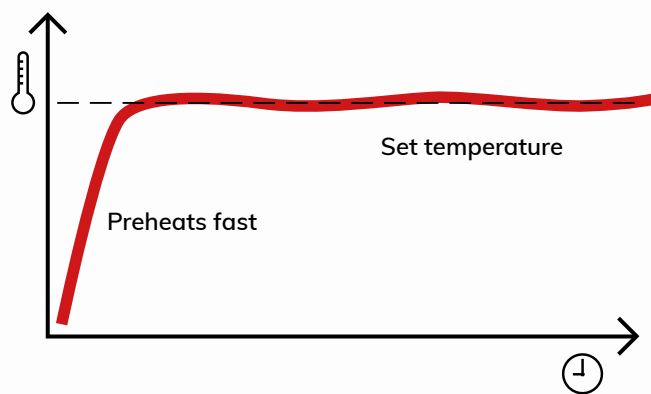

EXCLUSIVE

Dynamic control system - PID.

The PID system automatically and dynamically calculates exactly how much energy is required to maintain the temperature, keeping any small variations in check.

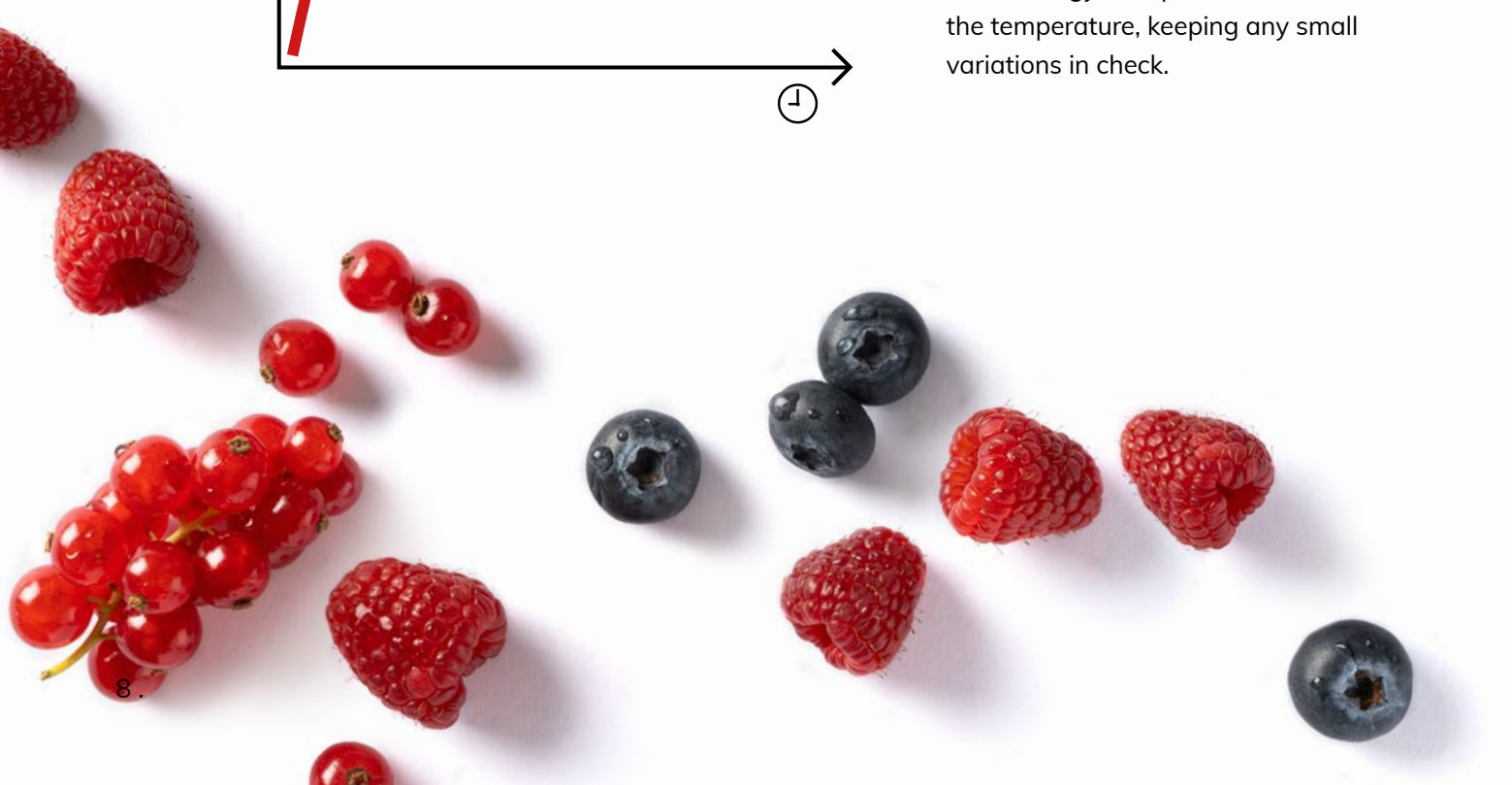

Designed to keep consumption down to a minimum



Features and systems

Automatic ON/OFF switching.

This can be set on a weekly basis, so that the oven is ready whenever you need it and stays off when you don't.

On standby: on hold but always ready for use.

This reduces energy consumption by lowering the temperature during downtimes, while also ensuring that the oven is ready for baking at short notice.

Dynamic self-regulation features.

The new Hybrid Control panel allows you to optimise oven consumption through advanced functions that manage energy dynamically and automatically.



Materials and components

Thermally-insulated viewing doors with low-emission glass pane.

They ensure maximum heat retention (optional).



Thermal insulation panels.

Heat loss minimised with wool compressed to a density of 100 kg/cubic metre.

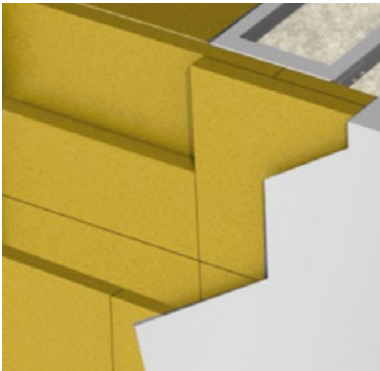

Heat-retention vault in the oven mouth.

Arched ceiling to reduce heat loss (available with Super Power).



This is what an intelligent heat system does

The best technology for chamber heat control: a flexible, dynamic and smart system.

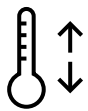

INTERNATIONAL PATENT 

New dynamic energy-switching device (PRD).

Each oven chamber automatically adjusts the flow of energy, distributing it dynamically in order to maintain an optimal temperature.





Armoured closely-spaced heating elements in special steel.

The reinforced heating elements placed crosswise in close proximity significantly improve the evenness and overall distribution of heat.



EXCLUSIVE 

Dynamic heat regulation with the triple-zone system (TZS).

The triple-zone system (TZS) allows the oven to automatically balance out air temperature for uniform baking thanks to the dynamic regulation of energy in the mouth, at the centre and at the base of the chamber.

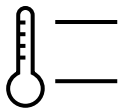

Independent control of ceiling/bedplate temperature and power.

You have separate control over the ceiling and bedplate, allowing you to set them differently according to your requirements and product type.

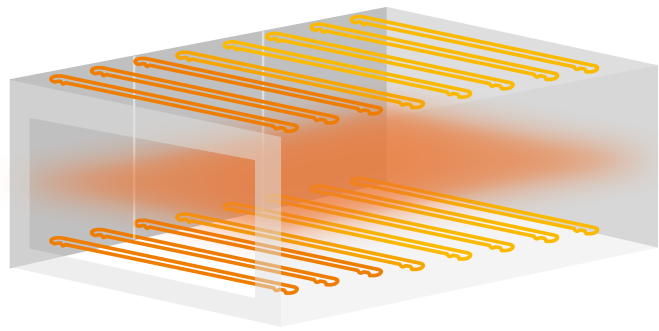

Stratos XP system with armoured and closely-spaced heating elements

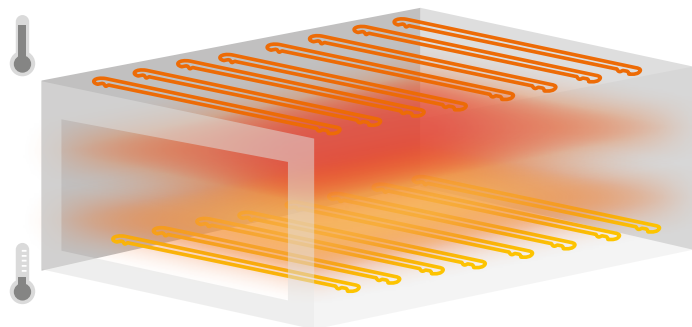
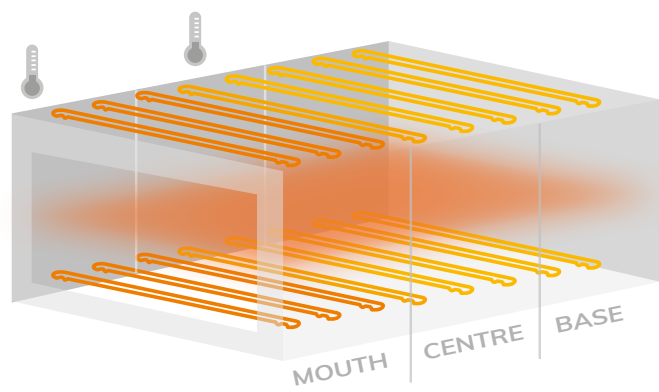

Hybrid Control. An oven at your fingertips

Hybrid Control is the new computerised control system with an even more intuitive and simpler interface featuring a 5" touch-screen monitor. With a high-powered processor, it allows you to easily control both standard and more advanced functions, making it easy to experiment with any setting.



Touch-screen.

New 5" touch-screen monitor and easy-to-use intuitive interface.



Fixed keys.

To allow the operator to work more quickly and efficiently, there are a number of fixed keys for those commands you always like to have at your fingertips.

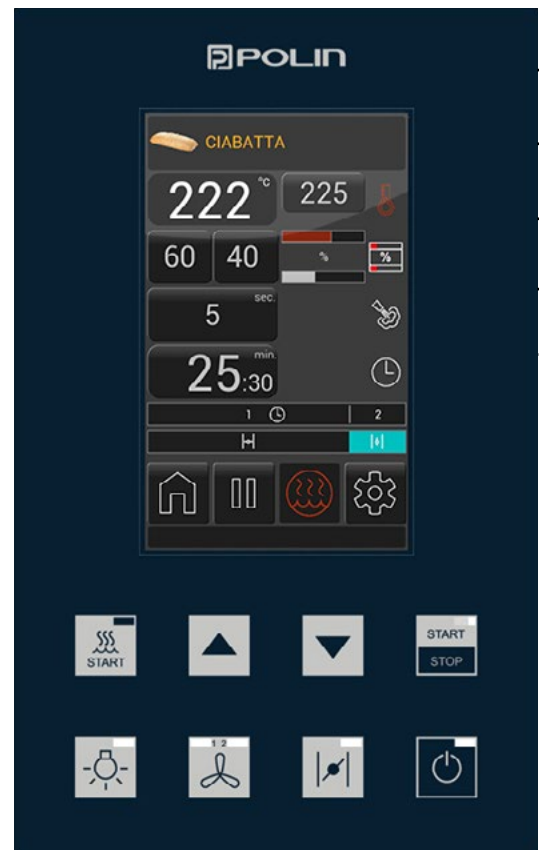



Dynamic QR Code for assistance.

Hybrid Control has a special function that puts the oven directly into contact with the relevant service centre. If the oven suffers any malfunction, a QR-Code appears on the control panel display: by scanning the code with a mobile device, you can send an email with all the necessary information and significant details that will be automatically generated, so that the problem can be properly assessed.

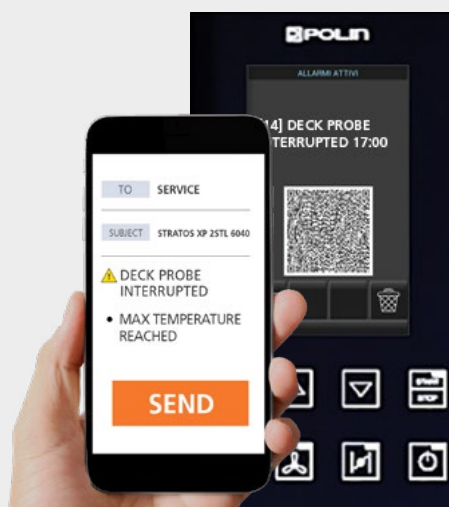

100 baking programmes with 10 stages.

You will be able to store all your favourite recipes and retrieve them effortlessly whenever you need them.

Programmable automatic actions, such as switching the oven on and off at set times.

Control and energy-saving functions.

For optimal oven settings that match product type and allow for the smoothest and most streamlined operation.

Interconnection and remote management of the oven.

Hybrid Control is designed for remote management and interconnection with other ovens and appliances via the BakeApp 4.0 software to create an Industry 4.0 system (optional).





All designed to give you the best

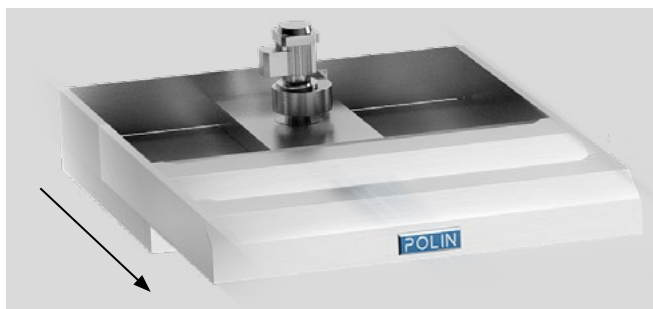

Extended steam extractor hood with removable grid

The hood can protrude up to 400 mm – a value to be set during assembly – for the extraction of ambient steam during product baking operations (optional).



Tempered glass viewing door

Made of low-emission glass to retain the heat in the chamber and allow a complete view of the product being baked.



Recessed viewing doors for ease of use

The recessed opening system prevents accidental contact – a typical issue with tilting doors.



Practical removable rack

Facilitates operations during product loading and unloading from the oven (optional).

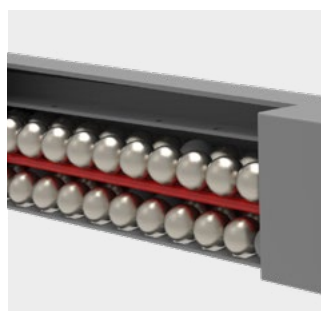

Steamer built into the chamber

The pulse steamer ensures high efficiency and generates a considerable amount of heat that can quickly supply the chamber with saturated steam (optional).

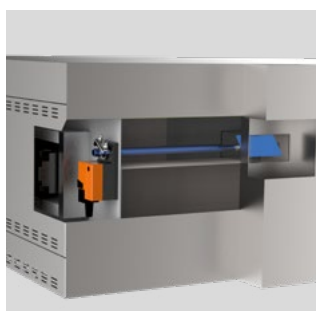

Automatic steam discharge valve

This allows the shutter to partially or completely open, allowing manual or automatic discharge of steam according to the recipe.

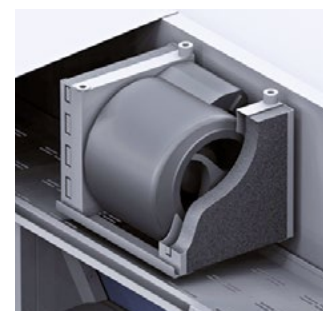

Steam reduction kit with charcoal filter

Dry-air steam condenser with activated carbon (additional option).



Latches on the mouth for the loader.

The oven can be used with a manual loader.



Proofing chamber controlled by the oven panel with automatic temperature/ moisture regulation (optional)

The proofing chamber is made entirely of stainless steel with an internal fan system for improved air distribution.

With controls on the oven panel, this allows you to set the time, temperature and moisture percentage. The spacing between the racks can be adjusted in height.

FAST integrated oven

Made of stainless steel and balanced for hassle-free use, it allows a single operator to quickly and manually perform normal oven loading operations. By choosing the appropriate loader, you can automate the unloading process as well.

In the rest position, the integrated oven is located at hood level and therefore does not occupy any floor space.

Available for ovens with up to 5 chambers.



+ OTHER FEATURES

Stainless steel front and side cladding

Casters for ease of movement.

Which model do you need?



Materials and components

- | |
|--|
| <ol style="list-style-type: none">1. Hood without extractor2. Hood with extractor3. Upper insulator4. Hood with air-operated condenser |
| <ol style="list-style-type: none">5. 17/22 cm chamber with thermally-insulated viewing door6. 17/22 cm chamber with glass viewing door |
| <ol style="list-style-type: none">7. Baking plate in perforated sheet metal (400°C)8. Baking plate in fibre cement (300°C)9. Baking plate in refractory material (450°C)10. Baking plate in reinforced concrete (400°C) |
| <ol style="list-style-type: none">10. Lower insulator11. Wheeled base (4 heights avail.)12. Proofing chamber (73/93 height)13. Enclosed base (73/93 height) |
| <ol style="list-style-type: none">14. Tray-carrier rack15. Lower element with removable shelf16. Tray-carrier box |



UPPER ELEMENTS (ALTERNATIVES)



BAKING CHAMBER



BAKING PLATES (ALTERNATIVES)



BASES (ALTERNATIVES)

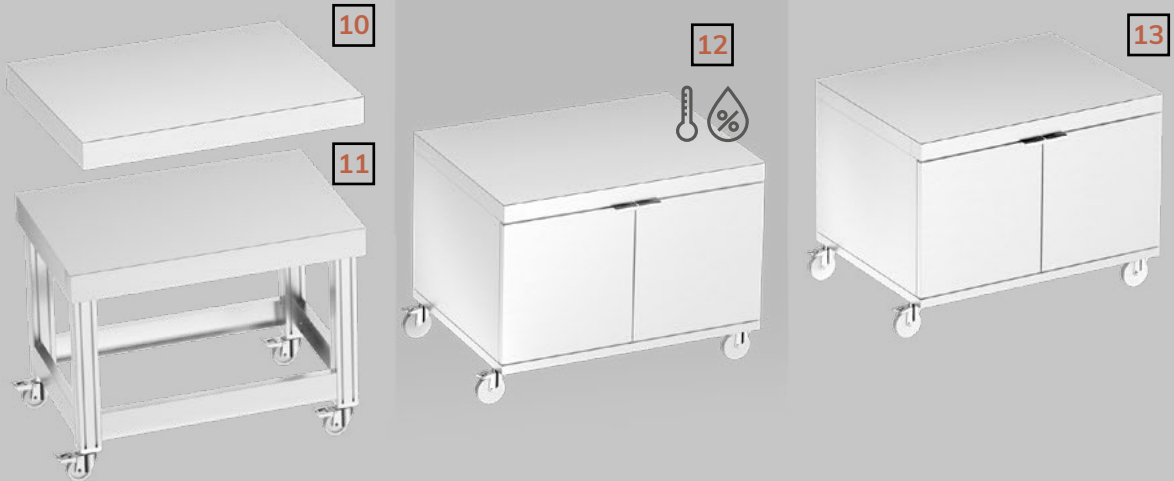

OTHER OPTIONS

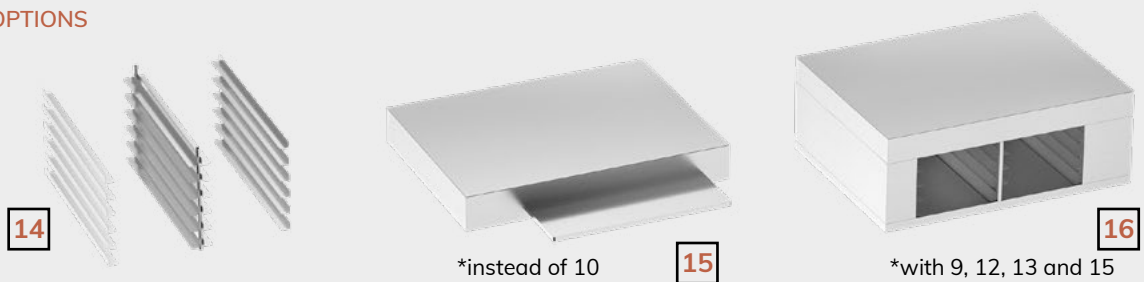



POLIN

250 °C 250

60 40

5 sec

25:30 min

1 2
H H

IN RISCALDAMENTO PANE

START

START
STOP

START

STOP

In Shop. The best corner of your store

The oven is the place where all your work comes *together*, where your customers look on, waiting to see something hot and fragrant come out. Such an important part of your store really needs to look good. Stratos XP is also available in different finishes which can be chosen to match your existing interior décor.

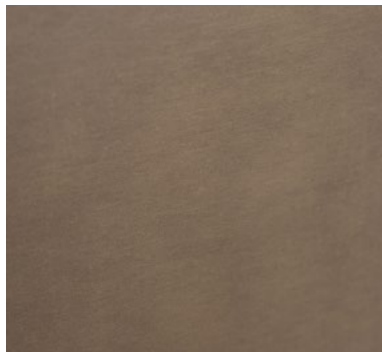
Satiny black**Shotblasted bronze****Dune blue (carbon look)**



CHAMBER CONTROL

Command keyboard	5" HYBRID CONTROL TOUCH SCREEN
Maximum temperature with glass viewing door	300°C
Maximum temperature with thermally-insulated viewing door	450°C (with refractory material)
Baking programmes with 10 stages (password-protected)	100°C
Fast pre-heating function (booster with Super Power)	○
Energy level	*
Standby energy function	*
Programmable on/off switch (twice a day on a weekly basis)	*
Independent control over ceiling and bedplate temperature	*
Automatic patented energy-switching device (PRD)	*
Timer that beeps when the baking time is up	*
Dynamic energy regulation system in the chamber (TZS triple-zone system)	*
Mouth temperature regulation via thermocouple	*
Alarms with fault display and a patented dynamic QR-Code system	*
Designed for remote management and BakeApp 4.0	*

MATERIALS AND COMPONENTS

Stainless-steel front panel	*
Special IN-SHOP front panel (electro-coloured steel or specially shaped sheet metal)	○
Latches on the mouth for the manual device	*
Detachable shelf	○
Hood with steam extraction and removable grid	○
Oversized fan for extractor hood (standard on 6ST 4060 hood)	○
High-density thermal panel insulation	*
Dry-air operated steam condenser built into the hood	○
Viewing doors on mouth with low-emission double glass pane and ergonomic handles	○
Front/chamber extraction adjustment system for hood with extractor	*
Automatic on/off light switches with energy-saving system	*
Casters	*
Tray-carrier base with viewing door	○

HEATING SYSTEM

Armoured heating elements in reinforced steel	*
---	---

STEAM SYSTEM

Built-in oven steamer with high-efficiency pulse steam ingress	○
Open/close cycle with programmable automatic vapour-release valve	*
Steam reduction kit with charcoal filter	○

PROOFING CHAMBER (additional option)

Regulation of moisture percentage and proofing time	*
Tray-carrier racks with adjustable height	*

* STANDARD ○ OPTIONAL

FEATURES

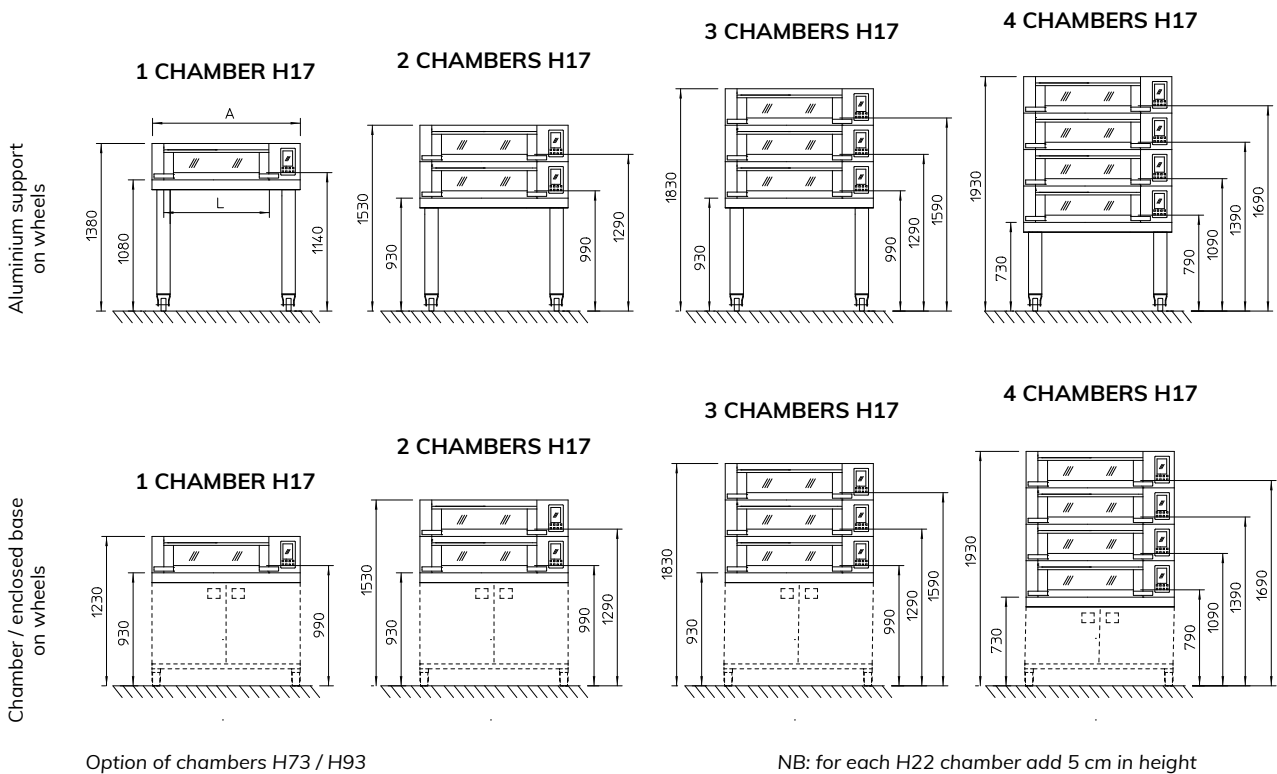

UPPER ELEMENTS

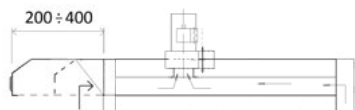

Extendible hood with or without extractor

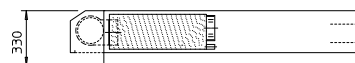

Hood with air-operated condenser

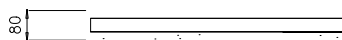

Upper insulator

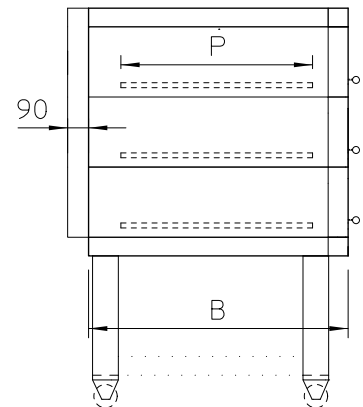

	A	B	L	P
2 STL 6040	980	1110	620	810
2 STA 4060	1220	910	830	610
3 STA 4060	1630	910	1240	610
3 STA 4680	1810	1110	1420	810
4 ST 4060	1220	1510	830	1210
4 STL 6040	1630	1110	1240	810
6 ST 4060	1630	1510	1240	1210

	TRAY CAPACITY		WEIGHT	Std POWER	MAX. POWER (Super Power)	POWER SUPPLY
	no.	mm	kg	kW	kW	kW
2 STL 6040	2	600x400	120	4.5	7	400/3N~/50
2 STL 6040 + Chamber	10-16		80-90	1		230/1~/50
2 STA 4060	2	400x600	130	4.8	6.8	400/3N~/50
2 STA 4060 + Chamber	15-24		80-90	1		230/1~/50
3 STA 4060	3	400x600	160	7	10	400/3N~/50
3 STA 4060 + Chamber	20-32		90-100	1		230/1~/50
3 STA 4680	3	460x800	180	9.9	15.4	400/3N~/50 /
3 STA 4680 + Chamber	10-16		100-110	1		230/1~/50
4 ST 4060	4	400x600	180	8.2	13.6	400/3N~/50
4 ST 4060 + Chamber	15-24		90-100	1		230/1~/50
4 STL 6040	4	600x400	180	9	14	400/3N~/50
4 STL 6040 + Chamber	20-32		90-100	1		230/1~/50
6 ST 4060	6	400x600	230	9.5	15.8	400/3N~/50
6 ST 4060 + Chamber	20-32		100-110	1		230/1~/50

TRAYS

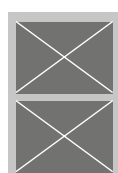

2 STL 6040

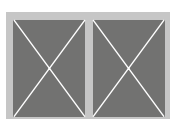

2 STA 4060

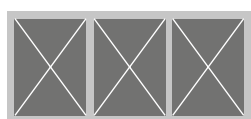

3 STA 4060 / 4680

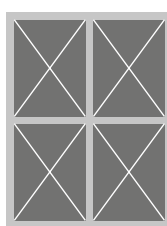

4 ST 4060

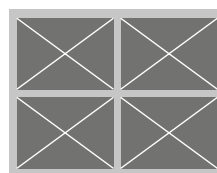

4 STL 6040

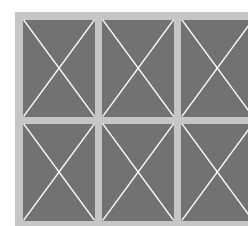

6 ST 4060

“We have always seen heat as an ingredient. And like all other ingredients, it must be of premium quality.”

A world-leader in the Art of Baking since 1929

We are the largest Italian manufacturer of ovens and machinery for the production of bread, pizza, pastries and biscuits.

We produce the most comprehensive, top-quality range of equipment for modern experts in the Art of Baking.

For over 90 years we have been offering the world the outstanding performance of technology conceived through our ingenuity.



POLIN GROUP

Ing. Polin e C. S.p.A.

Viale dell'Industria, 9 | 37135 Verona | Italy

Tel. +39 045 8289111 | Fax +39 045 8289122

polin@polin.it | www.polin.it

